



# ENERGY PLAZA

8610 & 8620 N NEW BRAUNFELS AVE, SAN ANTONIO, TX 78217

Up to 20,870 SF  
AVAILABLE



 **TRANSWESTERN** REAL ESTATE SERVICES





Home of the  
Petroleum Club

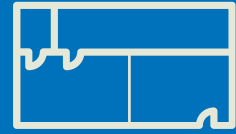

Move-in  
Ready Suites



Covered  
Parking



Easy Access to  
Loop 410 & Highway 281



Restaurant + Retail  
Options Nearby

Energy Plaza I & II consists of two mid-rise office buildings within the North central Submarket. The property sits off Loop 410 & Highway 281, with superior ingress and egress.



**ENERGY**  
PLAZA





# Location

The two building property is directly next to the San Antonio International Airport and is minutes from North Star Mall & Alamo Quarry Market. The property is within close proximity to over twenty eateries, significant shopping, and hotels within the airport district.

- Home of the Petroleum Club
- Three building conference rooms
- Tenant amenity break room
- On-site property management
- Structured parking garage

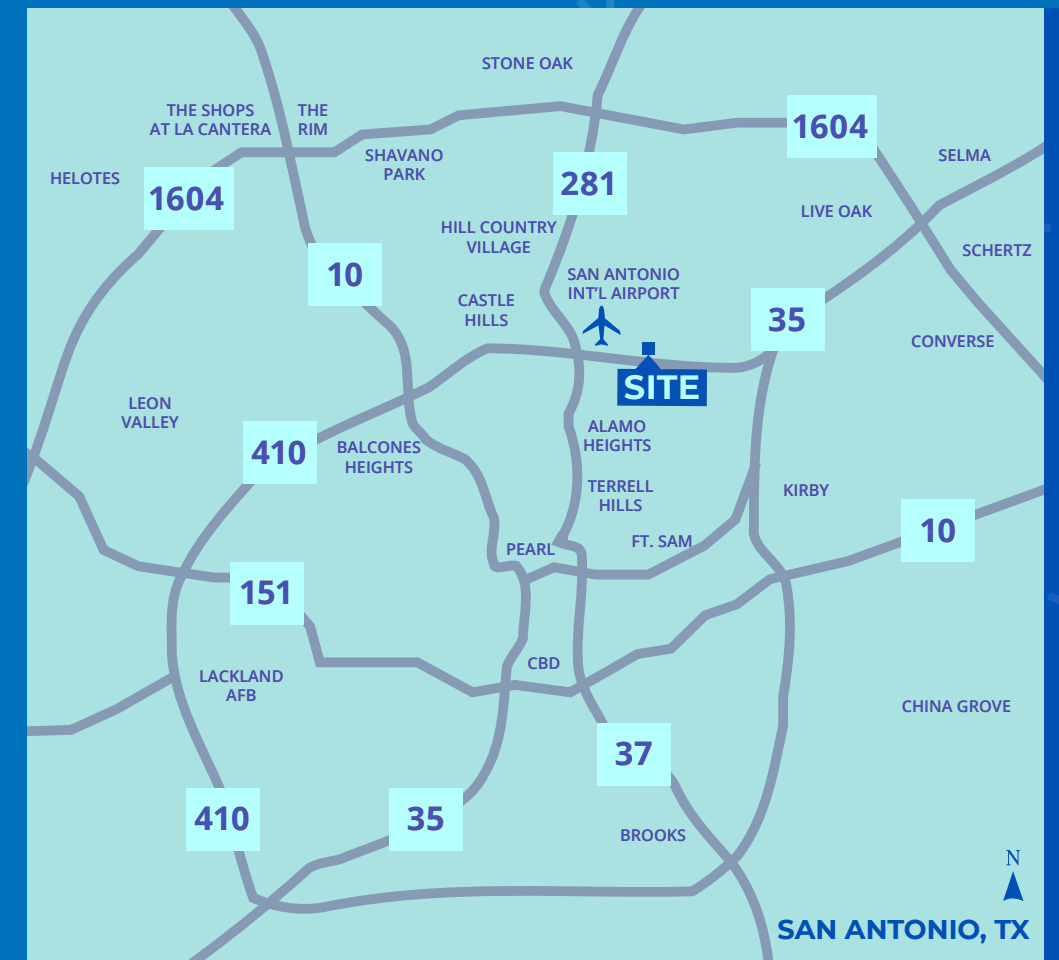



# INGRESS & EGRESS

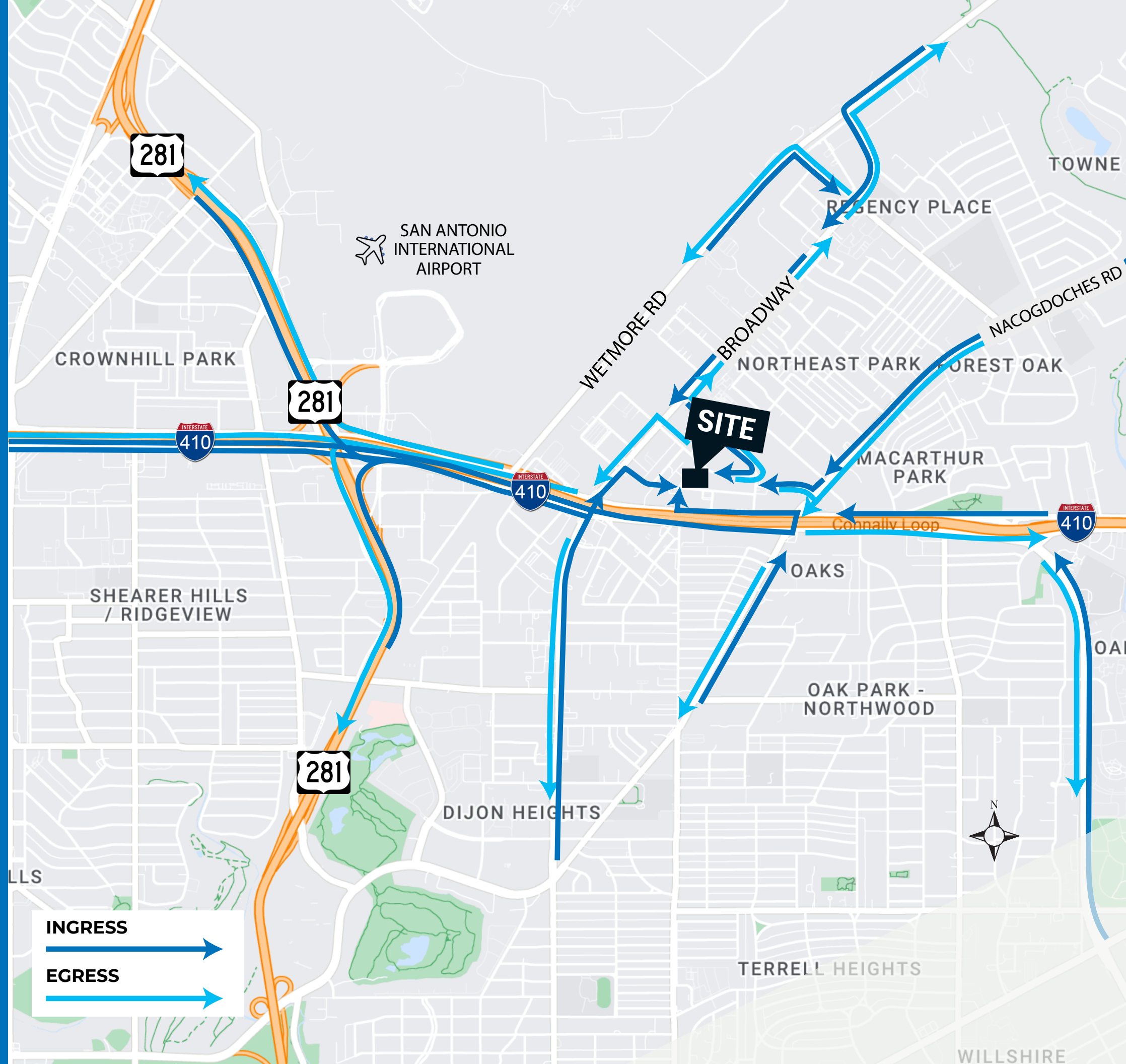

# ENERGY PLAZA I

FIRST FLOOR: N101 ±1,978 SF

Move-in Ready

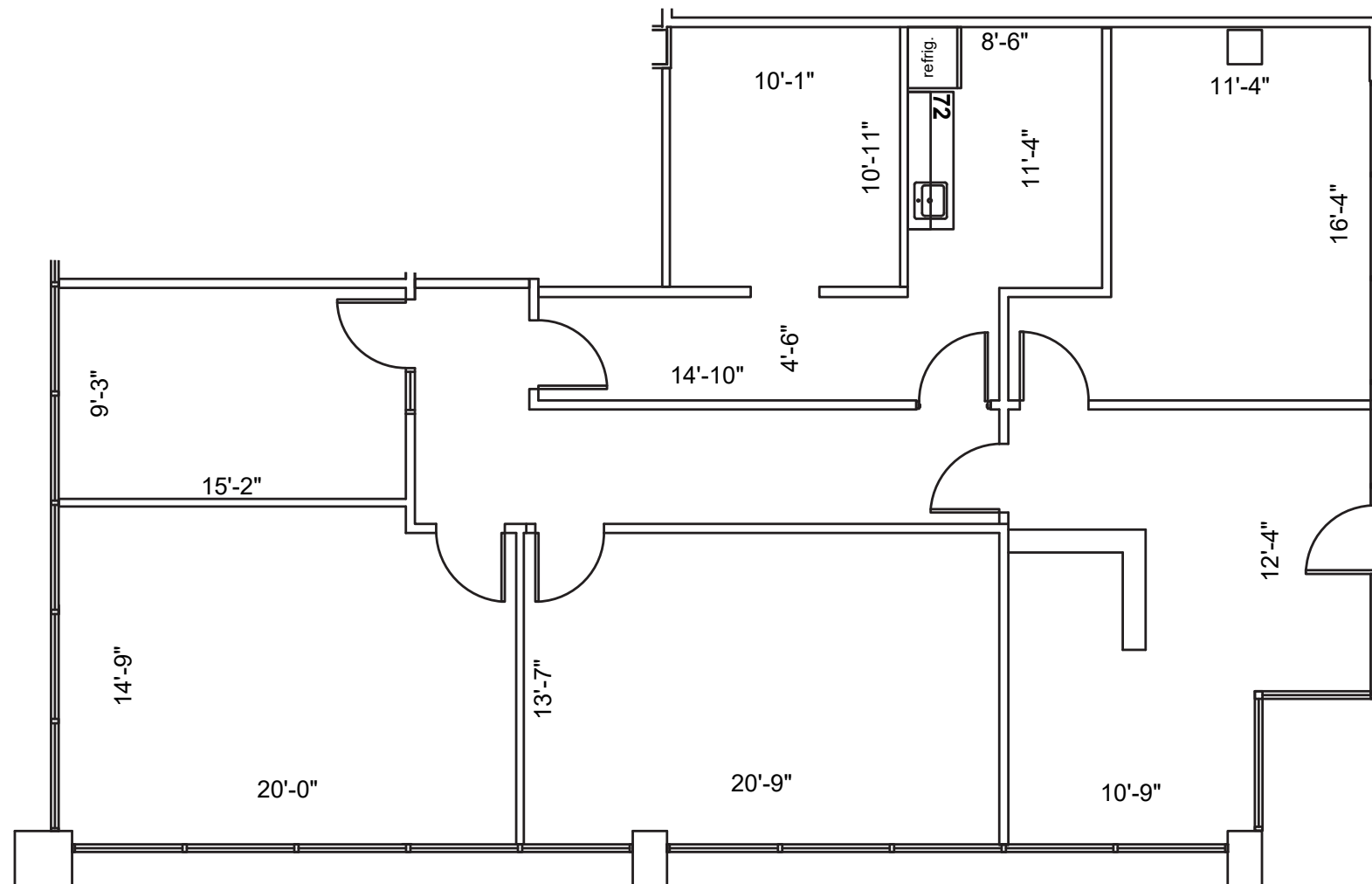

# ENERGY PLAZA I

SECOND FLOOR: N200 ±3,646 SF

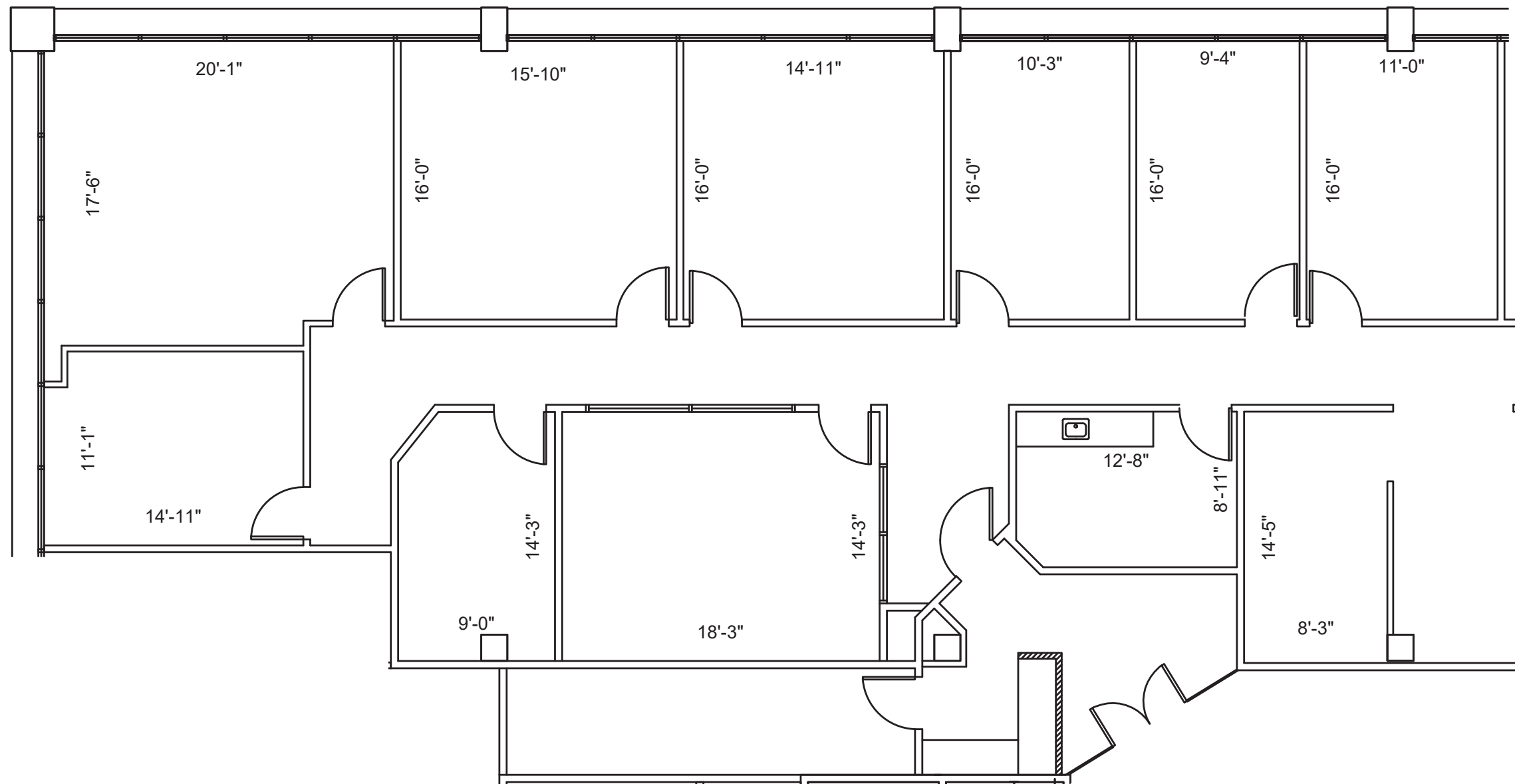

# ENERGY PLAZA I

SEOND FLOOR: N216 ±1,698 SF

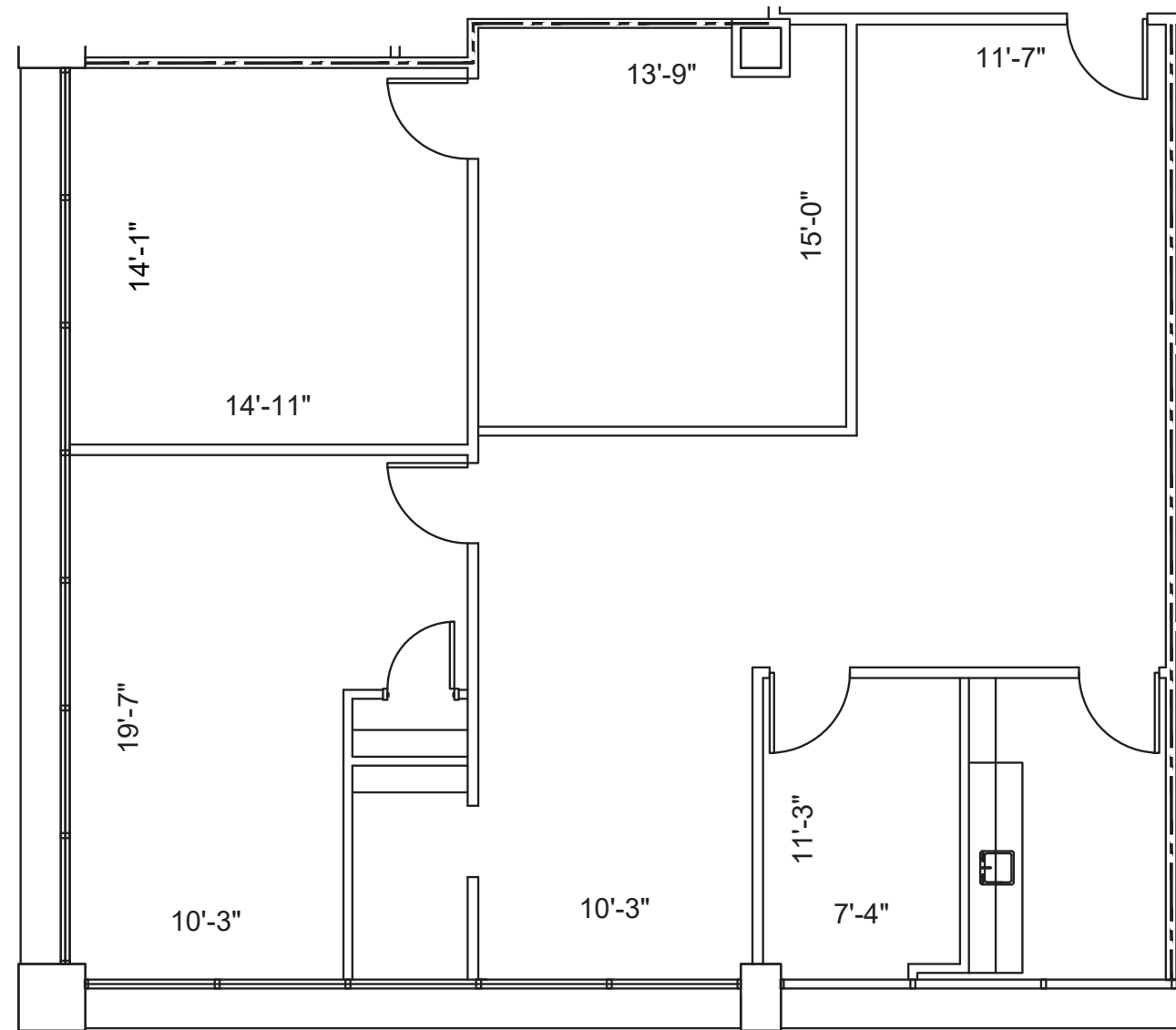

# ENERGY PLAZA I

THIRD FLOOR: N320 ±1,036 SF

Move-in Ready

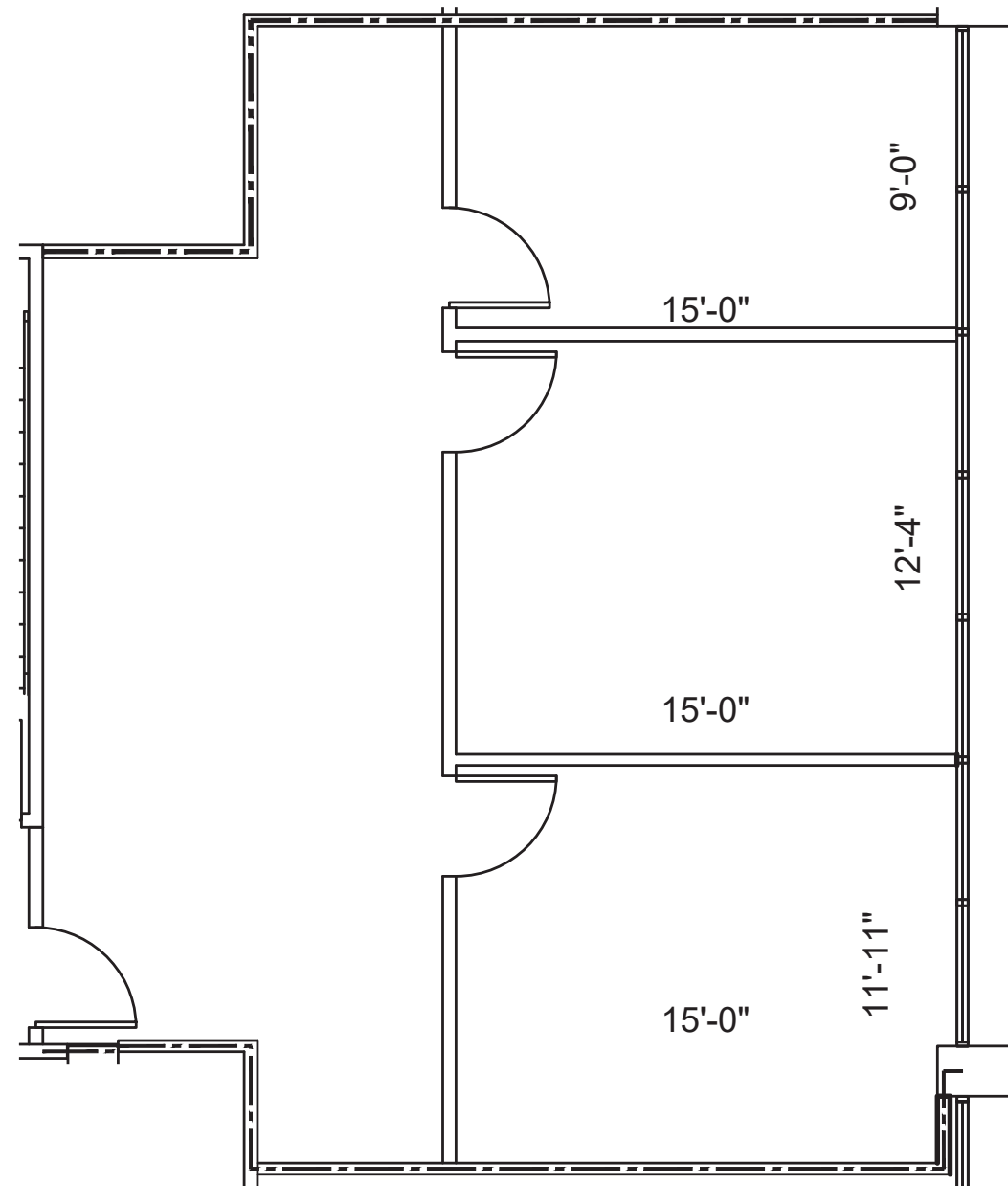



# ENERGY PLAZA II

FIRST FLOOR: S101 ±5,680 SF

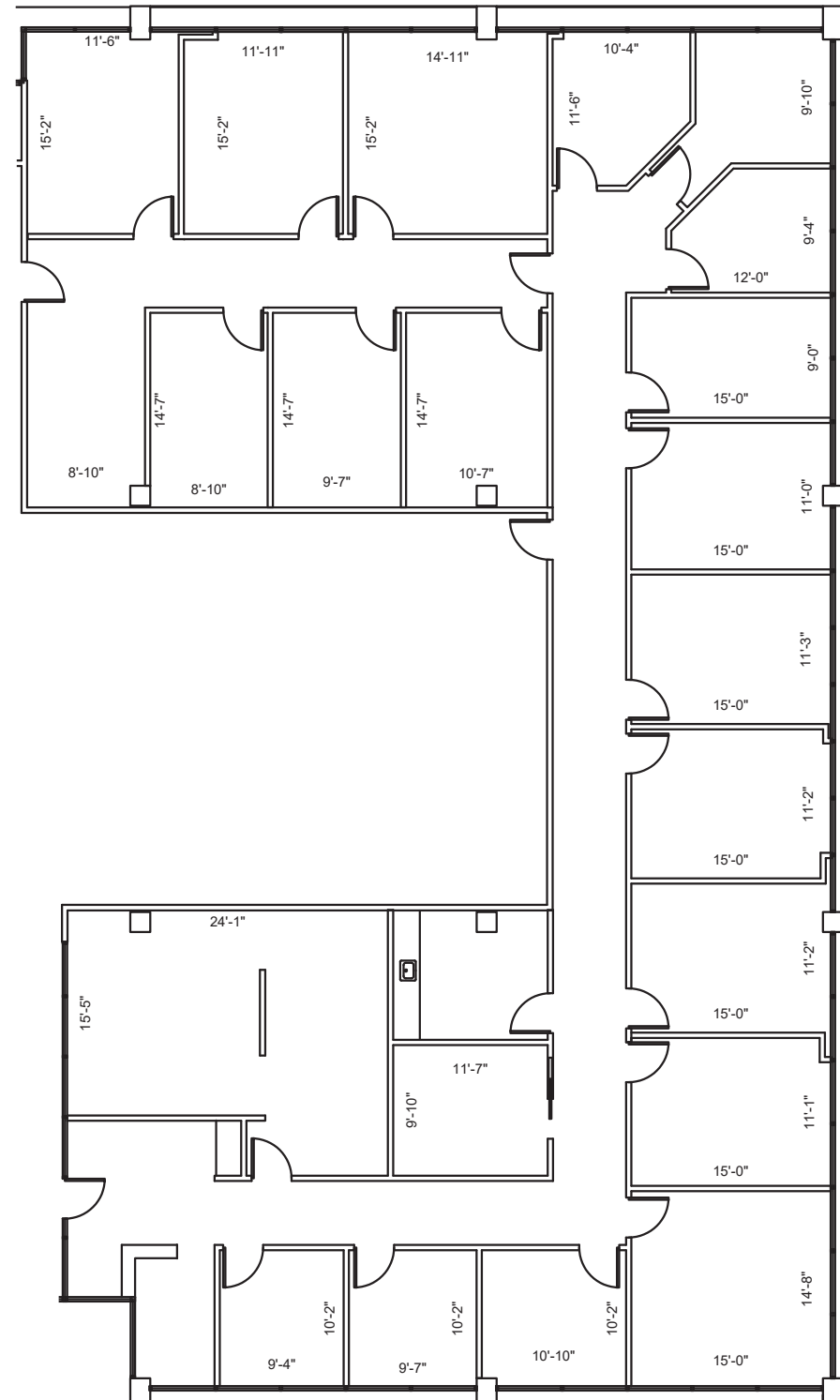



# ENERGY PLAZA II

SECOND FLOOR: S250 ±2,623 SF

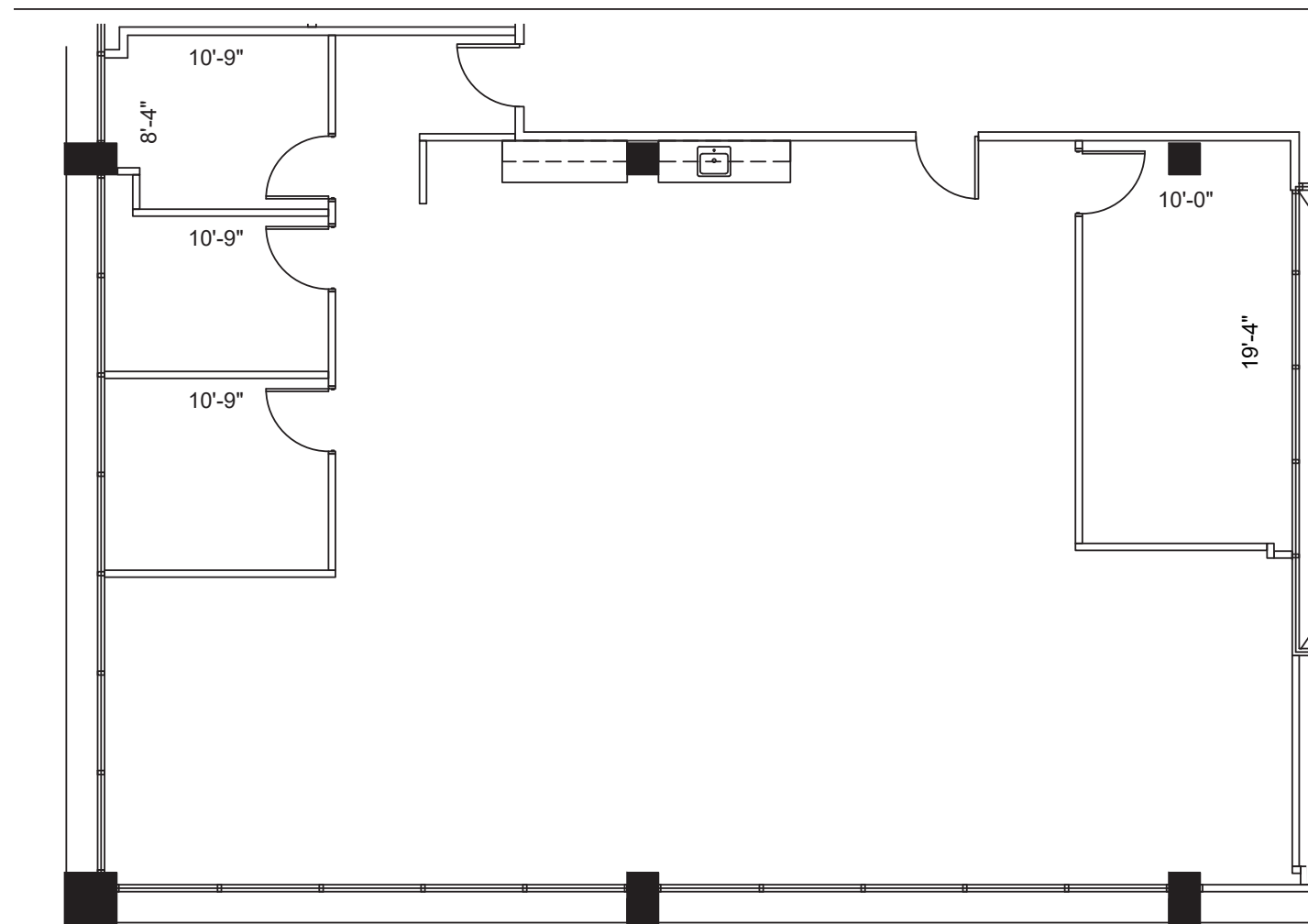



# ENERGY PLAZA II

THIRD FLOOR: S300/303 up to ±3,555 SF

**SUITE S300:**  
**2,079 SF**

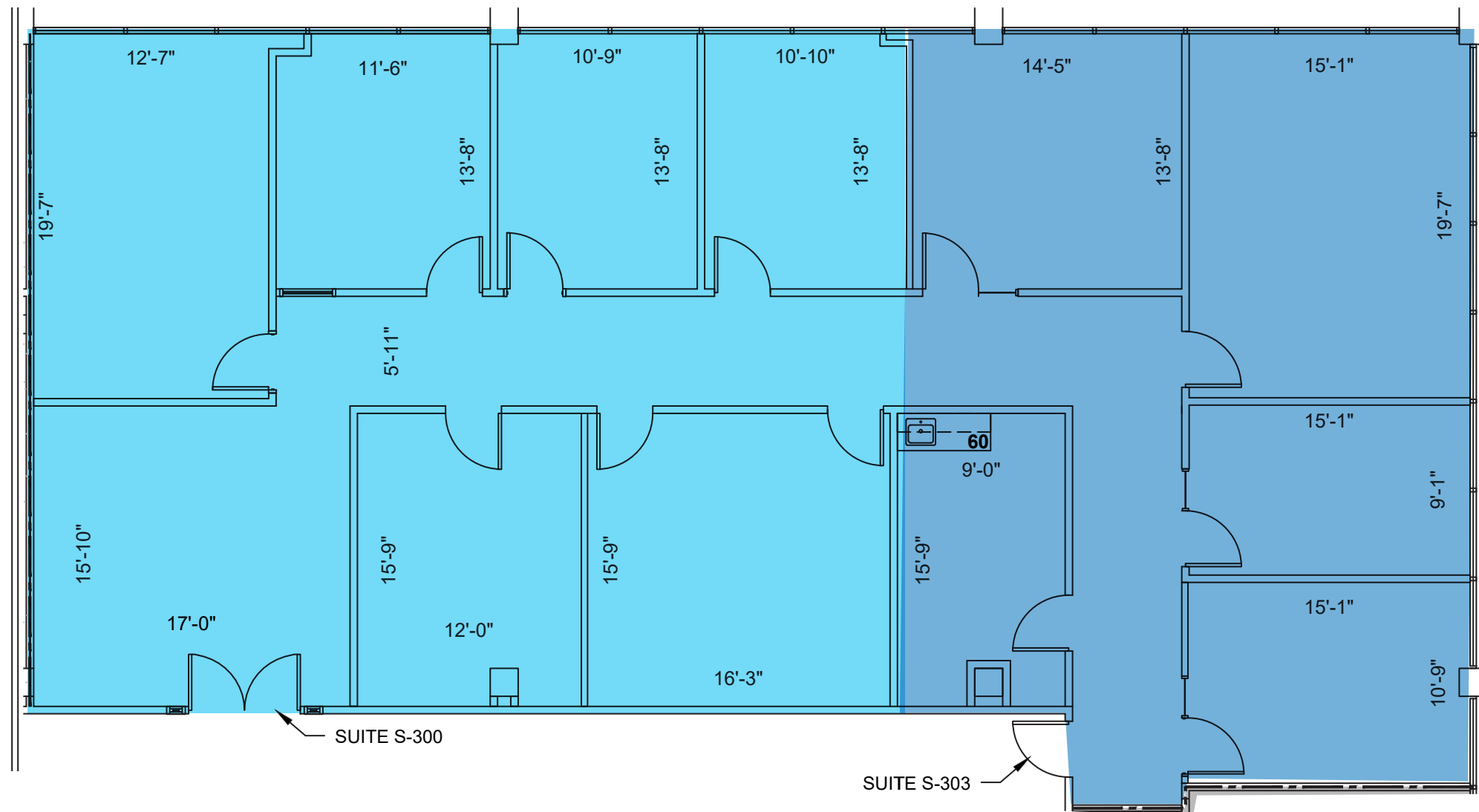

**SUITE S303:**  
**1,476 SF**



# ENERGY PLAZA II

SECOND FLOOR: S605 ±654 SF

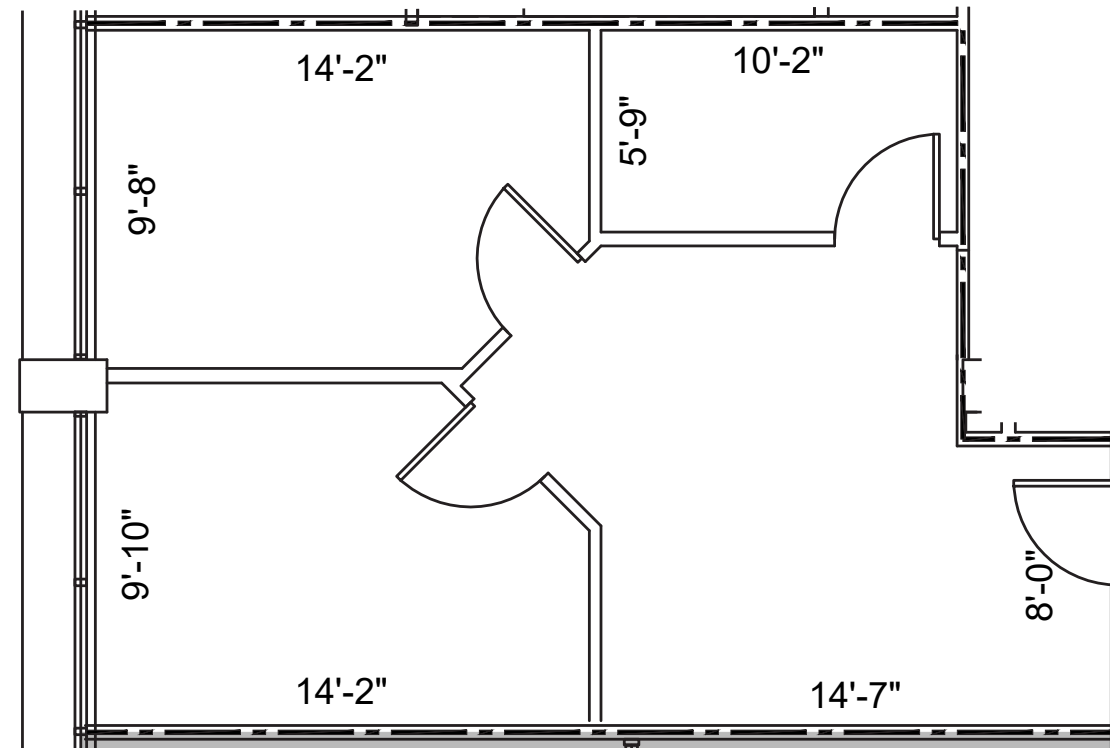





# ENERGY PLAZA

**8610 & 8620 N NEW BRAUNFELS AVE, SAN ANTONIO, TX 78217**

**KELLY RALSTON**

P: 210.253.2928

E: [Kelly.Ralston@transwestern.com](mailto:Kelly.Ralston@transwestern.com)

**MASON POLLARD**

P: 210.253.2935

E: [Mason.Pollard@transwestern.com](mailto:Mason.Pollard@transwestern.com)

**YESENIA M. SMITH**

P: 210.563.7070

E: [Yesenia.Smith@transwestern.com](mailto:Yesenia.Smith@transwestern.com)