

TRANSWESTERN
REAL ESTATE SERVICES



Cub LIQUOR

Cub FOODS

Burlington

\$5 TAN

Papa Murphy's

AFFORDABLE DENTURES & IMPLANTS

Chuck & Don's PET FOOD OUTLET

**OUTLOT 1
0.76 AC**

**Wendy's
UNDER CONSTRUCTION**

**Starbucks
xfinity
crumbl**

CHASE

CAFÉ ZUPAS

**at&t
PEARLE VISION**

Associated Bank

Southview Animal Hospital
GameStop
RED WING SHOES
Great Clips
PLAY IT AGAIN SPORTS
Hirshfield's
Metro Dentalcare

Associated Bank

S ROBERT ST

21,155 VPD

MENDOTA ROAD 9,000 VPD

White Castle

Walgreens



ROBERT STREET MARKETPLACE

Retail For Lease | West St. Paul, MN

JANET OLSON | 612.359.1681
TOM PALMQUIST | 952.381.5538

ROBERT STREET MARKETPLACE

OVERVIEW



SITE INFORMATION

Location: 2001-2067 South Robert Street | West St. Paul
Year Built: 1972
GLA: 172,354 SF
Parking: Surface Lot | 1,250 Stalls
Signage: Monument signage available to qualified premises



CENTER TENANTS

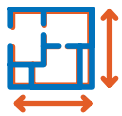

FOR LEASE

6,410 SF*
 17,715 SF* - Future
 7,826 SF
 3,922 SF

* CAN BE COMBINED

GROUND LEASE

0.76 Acres

2024 OPEX

CAM: \$2.89 PSF
Taxes: \$3.72 PSF
TOTAL: \$6.61 PSF



TRAFFIC COUNTS

South Robert Street: 21,155 vpd
Mendota Road: 9,000 vpd



DEMOGRAPHICS

	1 Mile	3 Mile	5 Mile
Population	7,236	73,481	187,460
Daytime Population	10,378	69,552	230,109
Median HH Income	\$51,079	\$66,338	\$68,083
Average HH Income	\$76,707	\$91,773	\$93,345

FOR INFORMATION CONTACT:

JANET OLSON | 612.359.1681
 janet.olson@transwestern.com

TOM PALMQUIST | 952.381.5538
 tom.palmquist@transwestern.com

SITE PLAN

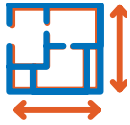

AVAILABILITY

- A: 6,410 SF*
- B: 17,715 SF* - Future
- C: 7,826 SF
- D: 3,922 SF

* CAN BE COMBINED

LOT 1: 0.76 AC



FOR MORE INFO CONTACT:

JANET OLSON | 612.359.1681 | janet.olson@transwestern.com
TOM PALMQUIST | 952.381.5538 | tom.palmquist@transwestern.com



SPACE PLAN UP TO 24,350 SF

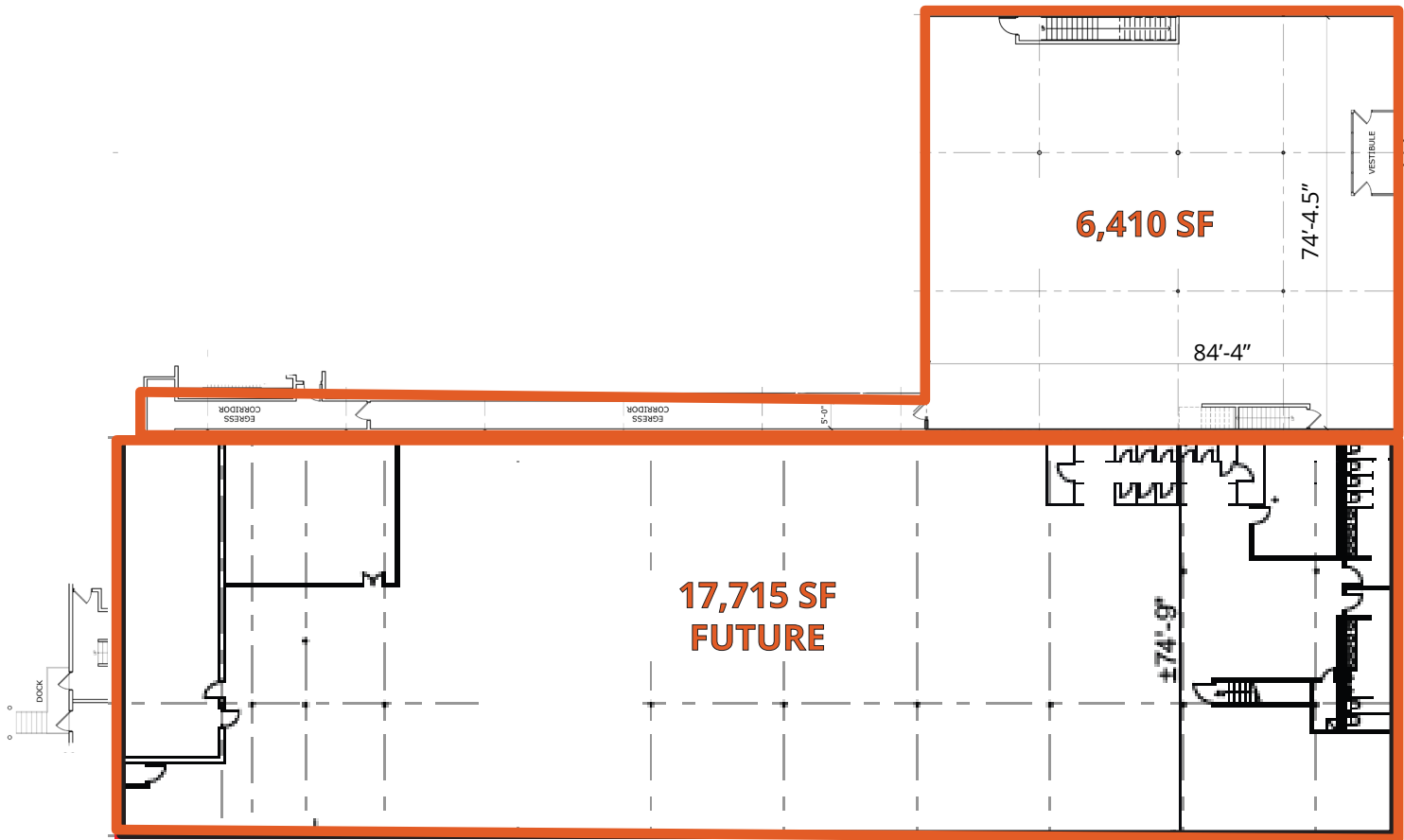

BUILDING KEY - SOUTH OF CUB FOODS

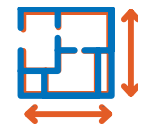

*Up to 24,350 SF

FOR MORE INFO CONTACT:

JANET OLSON | 612.359.1681 | janet.olson@transwestern.com
TOM PALMQUIST | 952.381.5538 | tom.palmquist@transwestern.com



SPACE PLAN 7,826 SF

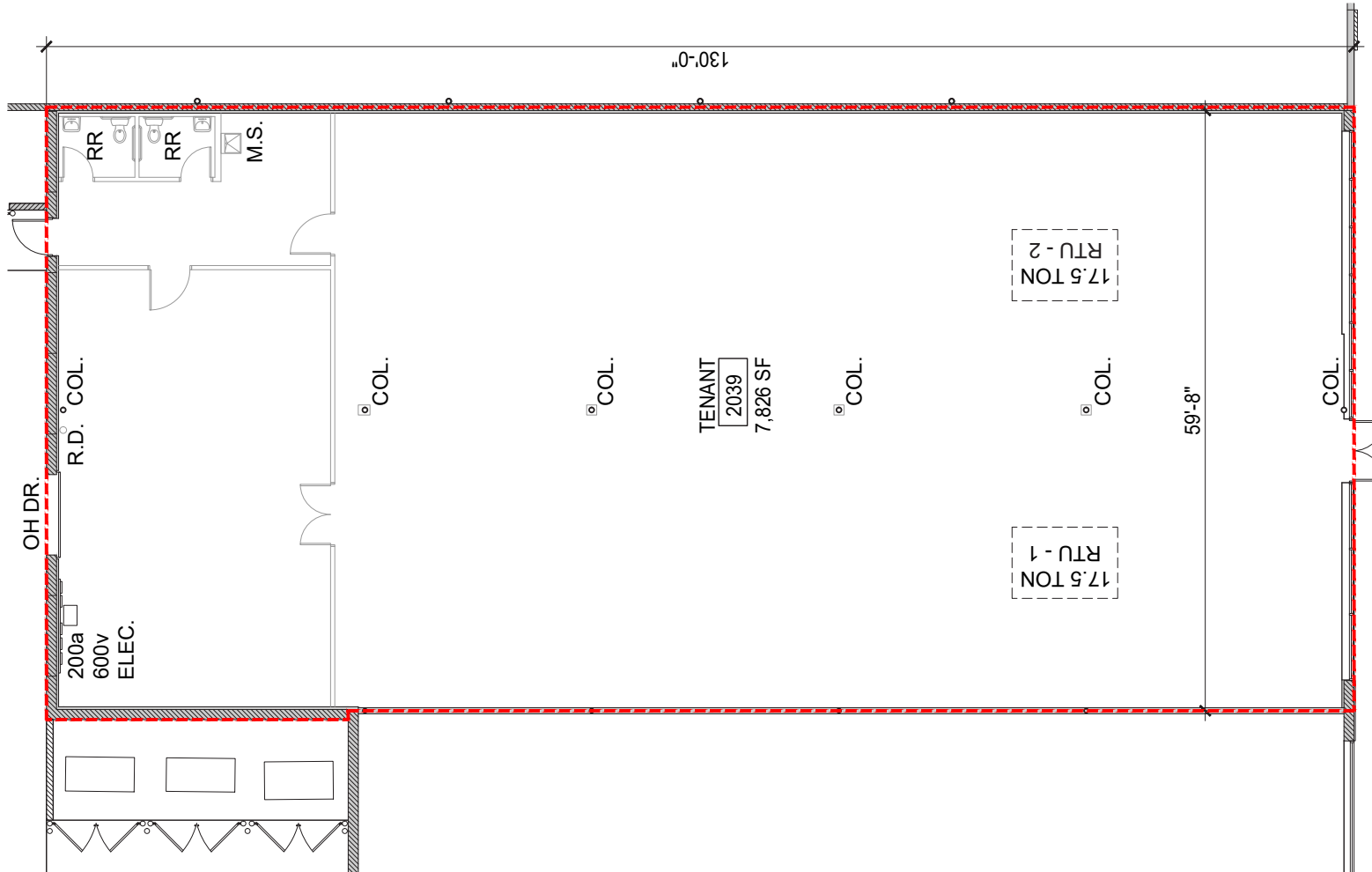

BUILDING KEY - SOUTH OF CUB FOODS

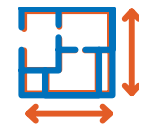

SUITE C
7,826 SF

FOR MORE INFO CONTACT:

JANET OLSON | 612.359.1681 | janet.olson@transwestern.com
TOM PALMQUIST | 952.381.5538 | tom.palmquist@transwestern.com



**REALTY
RESOURCES**
MEMBER

SPACE PLAN 3,922 SF

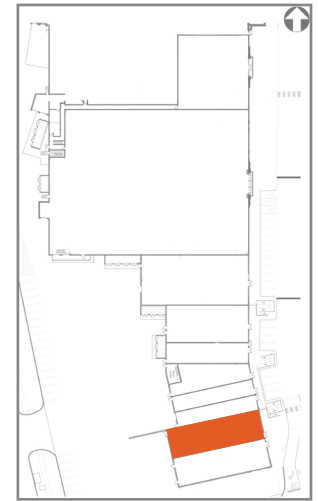
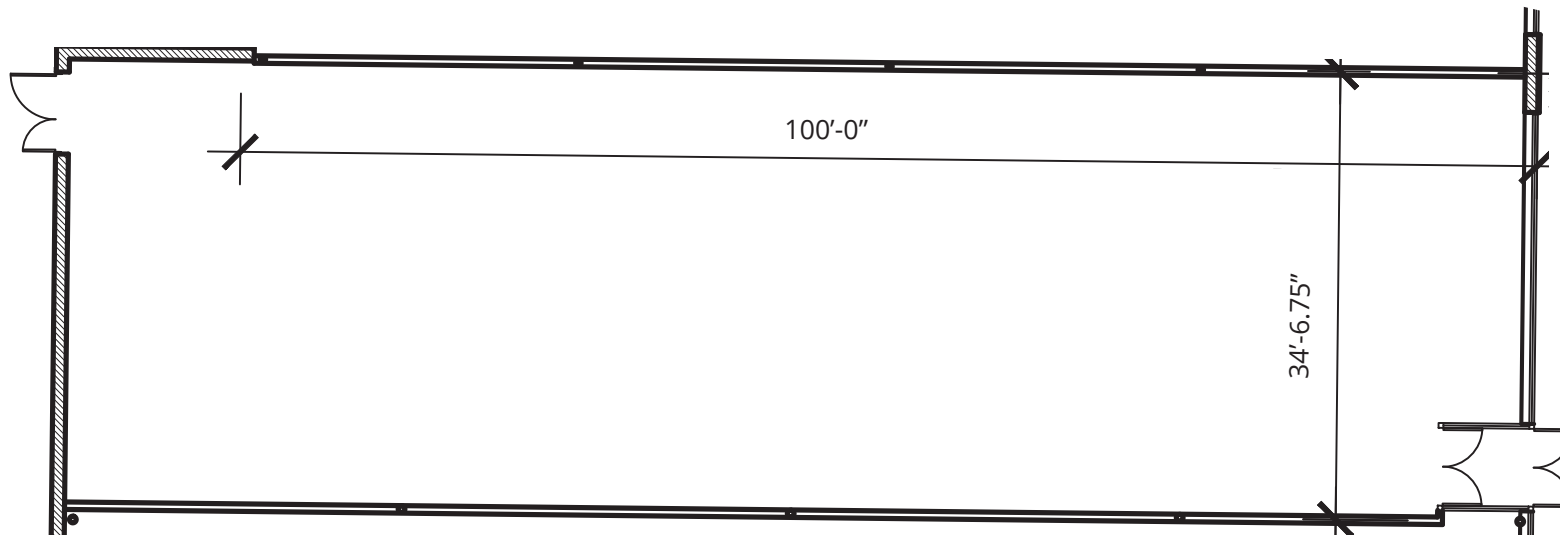

BUILDING KEY - SOUTH OF CUB FOODS

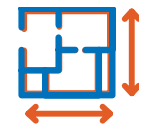

SUITE D
3,922 SF

FOR MORE INFO CONTACT:

JANET OLSON | 612.359.1681 | janet.olson@transwestern.com
TOM PALMQUIST | 952.381.5538 | tom.palmquist@transwestern.com



ROBERT STREET MARKETPLACE



FOR MORE INFO CONTACT:

JANET OLSON | 612.359.1681 | janet.olson@transwestern.com
TOM PALMQUIST | 952.381.5538 | tom.palmquist@transwestern.com



TRADE AREA AERIAL



FOR MORE INFO CONTACT:

JANET OLSON | 612.359.1681 | janet.olson@transwestern.com
 TOM PALMQUIST | 952.381.5538 | tom.palmquist@transwestern.com