

PREMIER MEDICAL SPACE FOR LEASE

# SIX WEST MEDICAL CENTER

601 W State Hwy 6, Waco, Texas 76710



welltower



# SIX WEST MEDICAL CENTER

601 W State Hwy 6, Waco, Texas 76710

Six West is a single story Class A medical office building in Waco, Texas near Ascension Seton Providence Hospital. The property offers great visibility and access from Hwy 6 and New Sanger Ave. Six West is located within close proximity to numerous amenities including restaurants, shopping, banks, retail, and other commercial services.

## Medical Office Availability:

- Suite 104 - 2,005 SF
- Suite 110 - 952 SF\*
- Suite 112 - 1,013 SF\*

\* Can be combined for 2,140 SF of contiguous space

## Building Information:

- Rental Rate: Contact broker
- OpEx: \$10.02/SF (2024 Est.)
- Parking: 3.54/1000

## Amenities:

- Covered Patient Drop Off Area
- Exterior Signage Opportunity
- Common Area Conference Room
- Surgery Center On Site
- Adjacent to Ascension Seton Providence Hospital
- Gated Physician Parking

Owned & Managed by **welltower**



# SIX WEST MEDICAL CENTER

601 W State Hwy 6, Waco, Texas 76710

Owned & Managed by **welltower**



## Suite 104 - 2,005 SF

SPEC SUITE

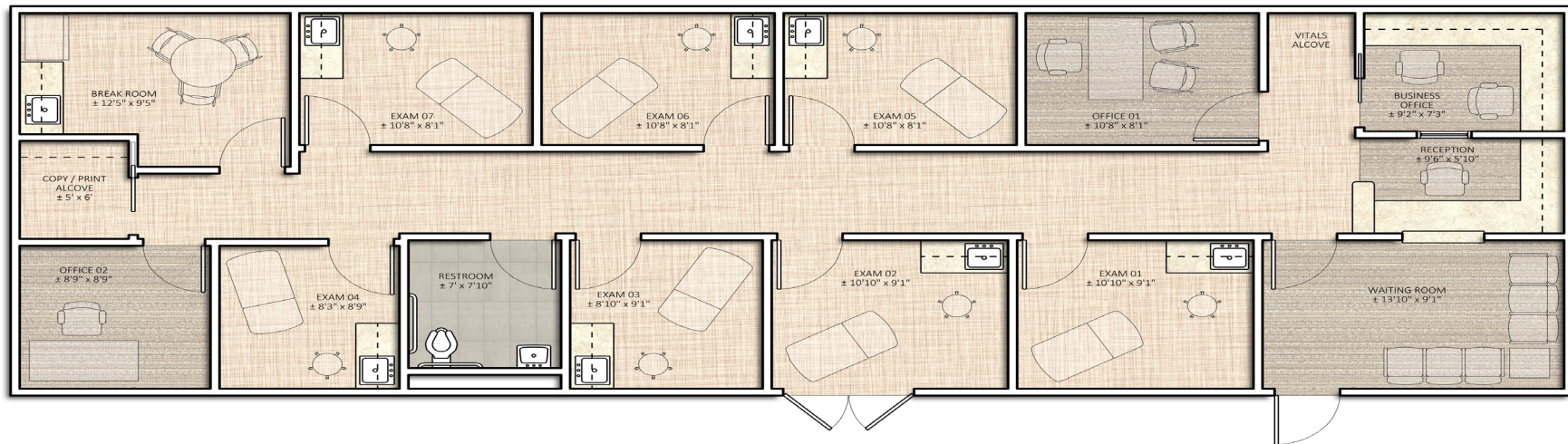

# SIX WEST MEDICAL CENTER

601 W State Hwy 6, Waco, Texas 76710

Owned & Managed by **welltower**



## Suite 110 - 952 SF

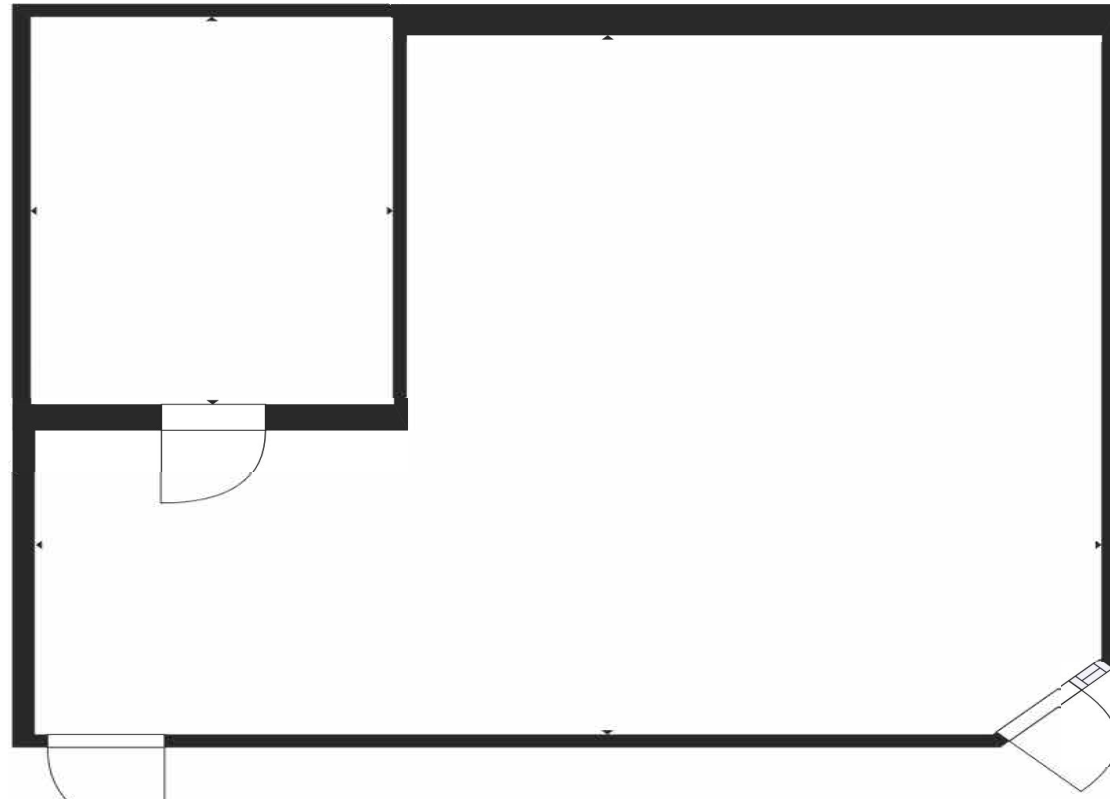

# SIX WEST MEDICAL CENTER

601 W State Hwy 6, Waco, Texas 76710

Owned & Managed by **welltower**



## Suite 112 - 1,013 SF

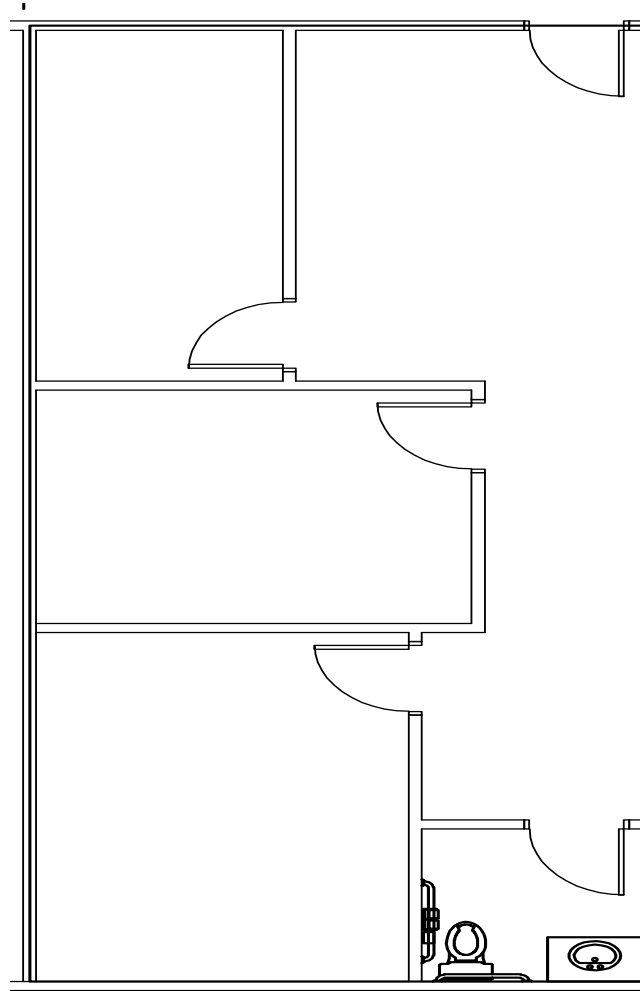

# SIX WEST MEDICAL CENTER

601 W State Hwy 6, Waco, Texas 76710

Owned & Managed by **welltower**



## Suite 110 & 112 - 2,140 SF

CONCEPT PLAN

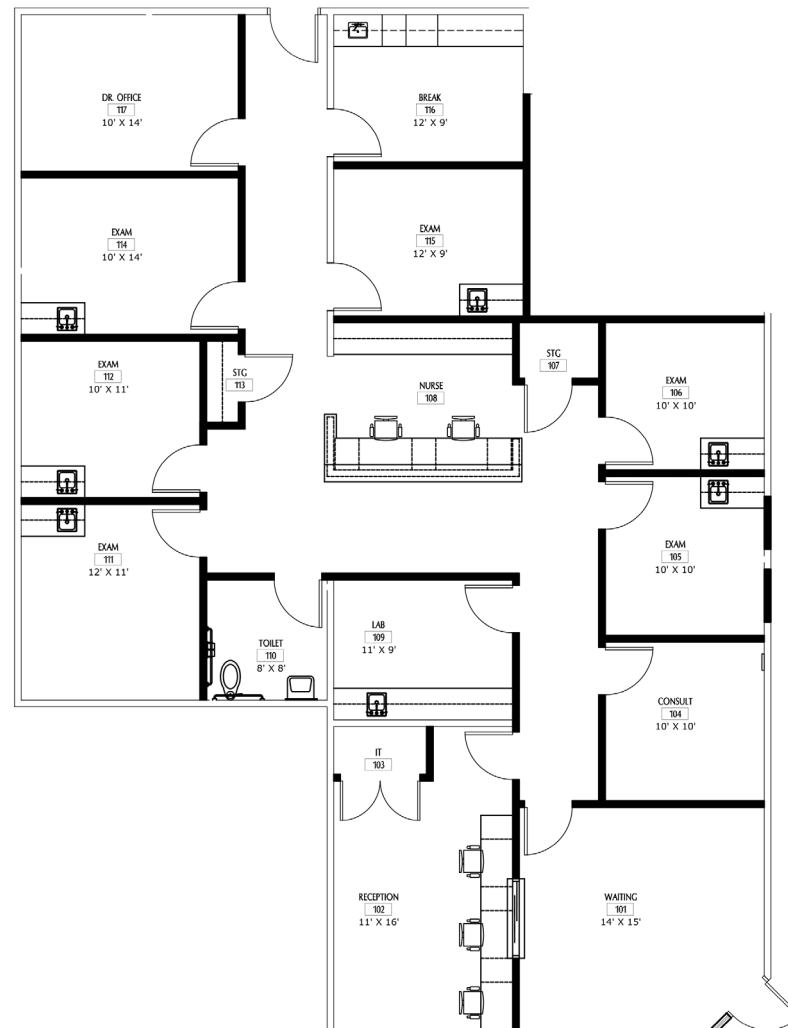

# SIX WEST MEDICAL CENTER

601 W State Hwy 6, Waco, Texas 76710

Owned & Managed by **welltower**

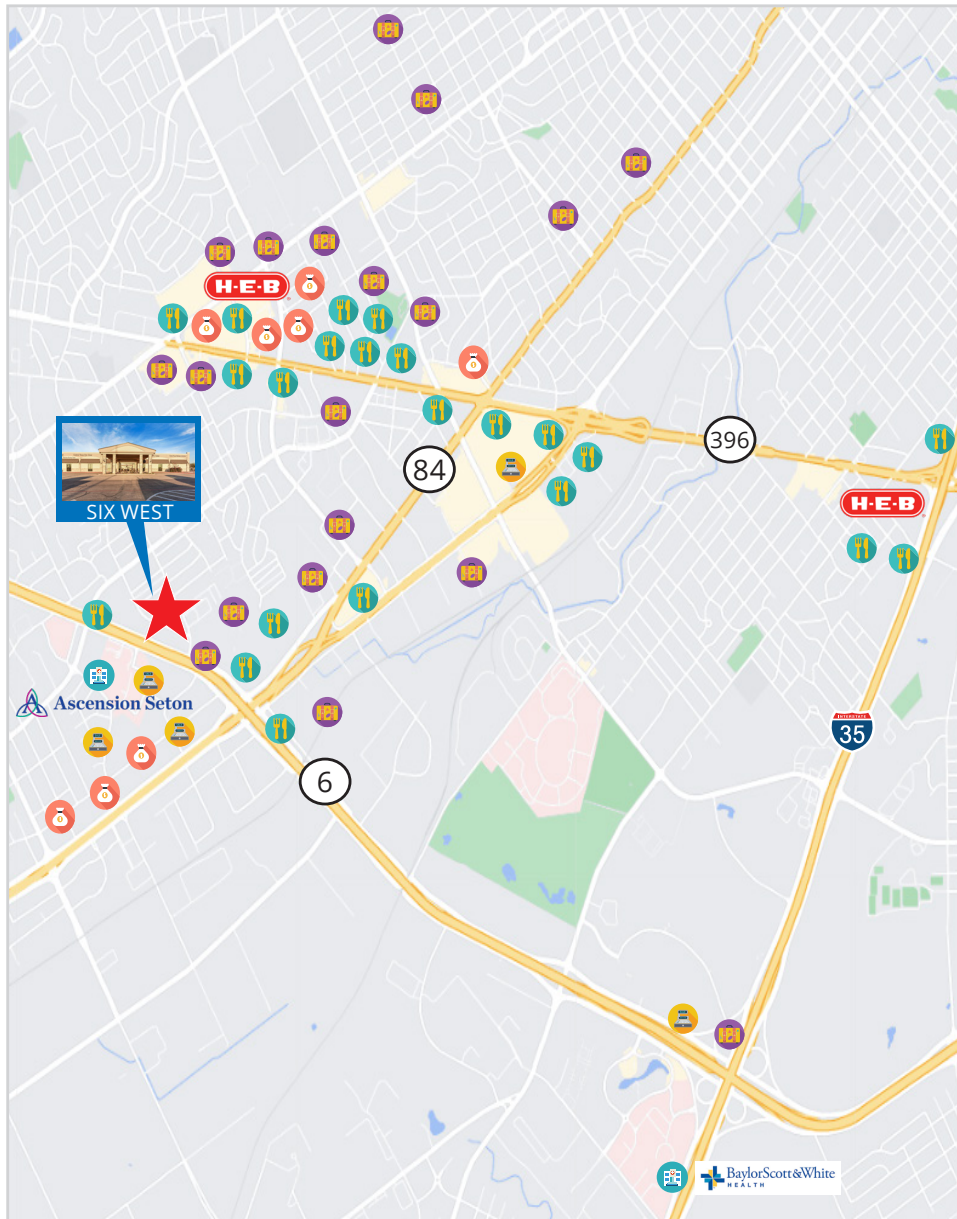

## HOSPITALS/CLINICS

- Ascension Seton Providence - 0.7 miles
- Baylor Scott & White Medical - 3.1 miles

## EATERIES

- Raising Cans
- Jack in the Box
- Wendy's
- Whataburger
- Taco Bueno
- Sonic
- Smoothie King
- Arby's
- Chick-fil-A
- Tom's Burgers
- Fuddruckers
- Long John Silvers
- Chipotle
- Arby's
- Chipotle
- Jason's Deli
- Taco Bell
- Hat Creek Burger Company
- BJ's Restaurant
- Dairy Queen
- McAlister's Deli
- McDonald's
- Firehouse Subs
- Panda Express
- Popeyes
- Bush's Chicken
- Subway
- Wingstop

## LODGING

- Hilton
- Holiday Inn
- Spring Hill Suites
- La Quina Inn
- Best Western

## SHOPPING/SERVICES

- Target
- Walmart
- HEB
- Kohls
- ALDI
- Aeropostale
- Barnes & Nobles
- JcPenney
- Burlington
- Buckle
- American Eagle
- Dillard's
- CVS
- T-Mobile
- Marshall's
- Journeys
- Walgreen's
- Lowe's
- Half Price Books
- Best Buy
- Foot Locker
- Dicks Sporting Goods
- Boot Barn
- Francesca's
- Hot Topic
- Hobby Lobby
- AT&T
- Joann
- Office Depot
- Zales
- Twin Liquors
- Claire's
- Bed Bath & Beyond
- Cavender's

## Banks

- Community Bank & Trust
- The First National Bank
- Central National Bank
- First Guaranty National Bank
- First Convenience Bank
- Texas First State Bank
- Alliance Bank
- Chase Bank
- Wells Fargo Bank

# SIX WEST MEDICAL CENTER

601 W State Hwy 6, Waco, Texas 76710

Owned & Managed by **welltower**

## Health Care & Insurance

This infographic provides a set of key demographic and health care indicators. Data sources include: American Community Survey (ACS) 5-year Data, Esri Consumer Spending, and Esri Market Potential data.

Learn more about this data: <https://doc.arcgis.com/en/esri-demographics/data/us-intro.htm>

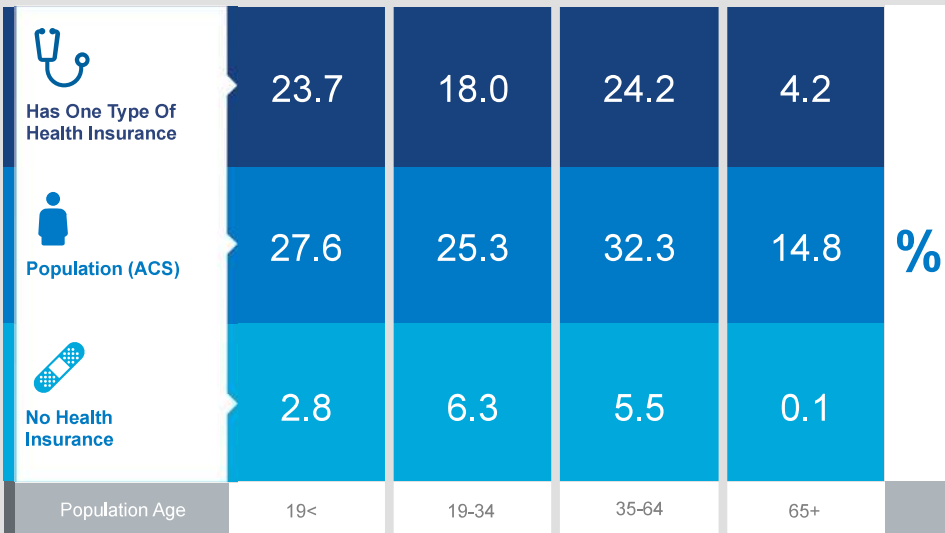

### Health Care Expenditure

**\$3,601**  
Annual Health Insurance Expenditures

**\$1,850**  
Medical Care

**Medicare:  
Population 65+**

**3,116**  
Medicare Only

**2,737**  
Direct-Purch & Medicare

**2,713**  
Employer & Medicare

**541**  
Medicare & Medicaid

### Health Care (Consumer Spending)

Annual Expenditure

Blue Cross/Blue Shield	\$930.1
Medicare Payments	\$727.0
Physician Services	\$223.9
Dental Services	\$345.1
Eyecare Services	\$61.7
Lab Tests/X-rays	\$62.5
Hospital Room & Hospital Service	\$181.3
Convalescent/Nursing Home Care	\$31.0

### Health Insurance Coverage (ACS)

● Pop 19-34 ● Pop 35-64

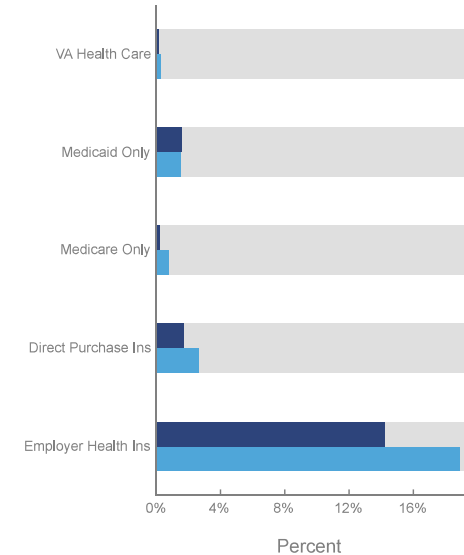

### KEY FACTS

**85,254**  
Population

**37.0**  
Median Age

**2.5**  
Average Household Size

**\$54,048**  
Median Household Income

### Exercise (Percent of Adults)



**38.6%**  
Exercise at home 2+ times per week



**12.4%**  
Exercise at club 2+ times per week

This infographic contains data provided by American Community Survey (ACS), Esri and Bureau of Labor Statistics, Esri and GIK MRL. The vintage of the data is 2016-2020, 2020. © 2020 Esri



# SIX WEST MEDICAL CENTER

601 W State Hwy 6, Waco, Texas 76710

Owned & Managed by **welltower**

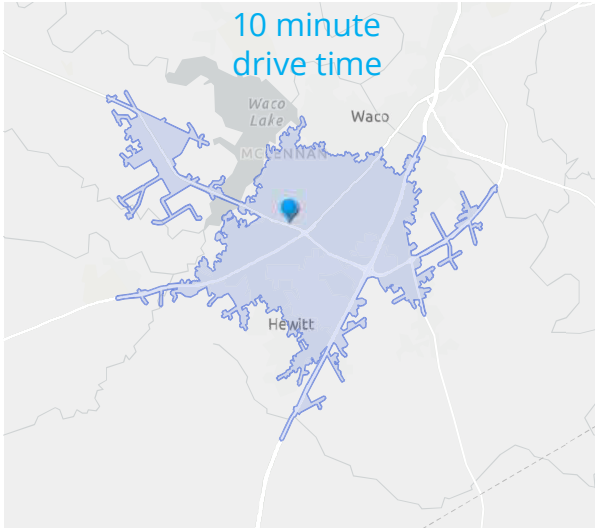

## POPULATION TRENDS AND KEY INDICATORS

601 W State Highway 6, Waco, Texas, 76710  
Drive time of 10 minutes

<b>85,254</b>	<b>32,595</b>	<b>2.52</b>	<b>37.0</b>	<b>\$54,048</b>	<b>\$179,421</b>	<b>70</b>	<b>117</b>	<b>80</b>
Population	Households	Avg Size Household	Median Age	Median Household Income	Median Home Value	Wealth Index	Housing Affordability	Diversity Index

### MORTGAGE INDICATORS

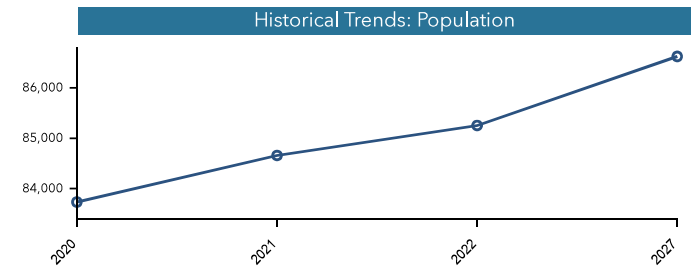

### POPULATION BY AGE

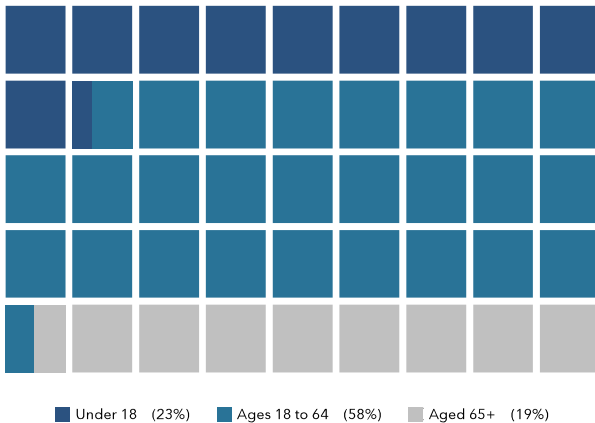

### POPULATION BY GENERATION

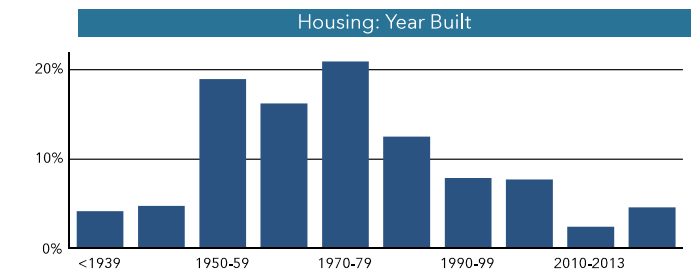
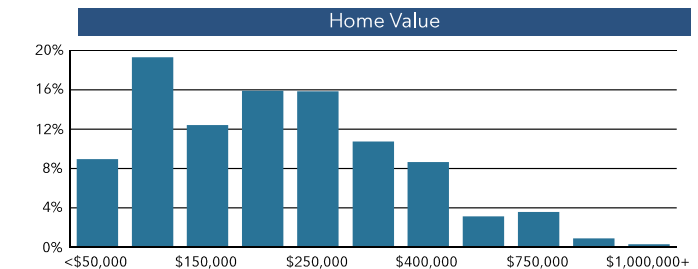
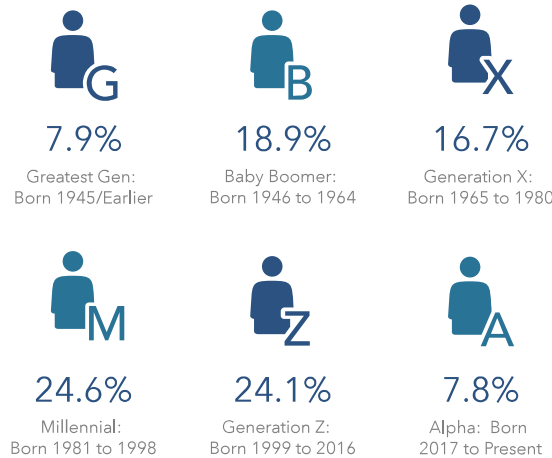

Source: Esri, Esri-U.S. BLS, ACS  
Esri forecasts for 2022, 2027, 2016-2020  
© 2023 Esri

# SIX WEST MEDICAL CENTER

601 W State Hwy 6, Waco, Texas 76710

Owned & Managed by **welltower**



## Demographic Report

601 W State Highway 6, Waco, Texas, 76710

	5 minutes	10 minutes	15 minutes
<b>Population</b>			
2022 Total Population	13,492	85,254	174,171
2027 Projected Total Population	13,619	86,623	178,193
2010 Total Population	12,361	75,822	153,388
2000 Total Population	12,210	72,123	140,683
2022 Total Daytime Population	29,148	113,385	193,253
2022-2027 Projected Annual Growth Rate	0.2%	0.3%	0.5%
2010-2020 Annual Growth Rate	0.8%	1.0%	1.1%
2022 Median Age	38.6	37.0	33.9
<b>Income</b>			
2022 Median Household Income	\$49,850	\$54,048	\$51,844
2022 Average Household Income	\$65,753	\$78,542	\$79,836
2022 Per Capita Income	\$29,027	\$30,639	\$30,268
2022 Households Earning \$100,000+	14.1%	22.7%	24.2%
<b>Households</b>			
2022 Total Households	5,731	32,595	65,240
2027 Projected Total Households	5,777	33,110	66,842
2010 Total Households	5,424	29,151	56,926
2000 Total Households	5,654	27,925	52,301
2022-2027 Projected Annual Growth Rate	0.2%	0.3%	0.5%
2010-2020 Annual Growth Rate	0.8%	0.9%	1.1%
2022 Average Household Size	2.3	2.5	2.5
<b>Housing</b>			
2022 Total Housing Units	6,434	35,776	71,565
2022 Occupied Housing Units: Owner	36.5%	55.3%	54.9%
2022 Occupied Housing Units: Renter	63.5%	44.7%	45.1%
2022 Vacant Housing Units	10.9%	8.9%	8.8%
2022 Median Home Value	\$145,622	\$179,421	\$195,477
<b>Race and Origin</b>			
2022 African American/Black Population	22.6%	14.3%	16.0%
2022 American Indian/Alaska Native Population	0.7%	1.1%	1.0%
2022 Asian Population	1.4%	2.2%	2.7%
2022 Pacific Islander Population	0.1%	0.1%	0.1%
2022 White Population	52.5%	54.4%	55.0%
2022 Other Race Population	10.9%	13.5%	12.0%
2022 Population of Two or More Races	11.9%	14.4%	13.2%
2022 Hispanic Population	27.6%	33.8%	29.7%
<b>Occupation and Education</b>			
White Collar Population	54.2%	57.0%	59.0%
Population with Bachelor's Degree or Higher	25.0%	29.5%	30.0%
2022 Unemployment Rate	3.1%	4.3%	4.4%

Women's Health

**For leasing information, contact:**

**Brandon Lester**

Managing Director-Market Leader

(512)-314-3576

[brandon.lester@transwestern.com](mailto:brandon.lester@transwestern.com)

**Will Stewart**

Senior Vice President

(512)-314-3574

[will.stewart@transwestern.com](mailto:will.stewart@transwestern.com)

 **TRANSWESTERN**